

# BPW VB series axle units.

Axle loads from 9,000 kg to 12,000 kg.

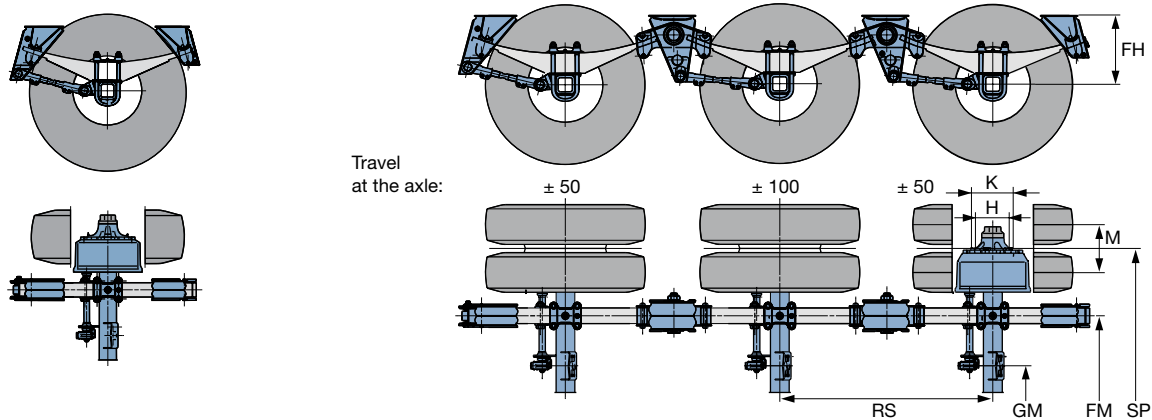

Type <sup>1)</sup>	Single axle	Tandem-axle suspension	Tri-axle unit	Version <sup>2)</sup>	Axle beam	S-cam brake Ø x width (mm)	Track (SP) (mm)	Spring centre (FM) (mm)	GM (mm)	Wheelbase (RS) (mm)	Tyre example <sup>3)</sup> (mm)
HSFVB	9,010	2/9,010	3/9,010	M / ME	120	SN 420 x 180	2,010	1,200	385	1,360	385/55 R22.5
HSFVB	9,010	2/9,010	3/9,010	M / ME	120	SN 420 x 180	2,040	1,200	415	1,360	385/55 R22.5
HSFVB	9,010	2/9,010	3/9,010	M / ME	120	SN 420 x 180	2,040	1,200	415	1,360	385/65 R22.5
HSFVB	9,010	2/9,010	3/9,010	M / ME	120	SN 420 x 180	2,095	1,400	470	1,360	385/55 R22.5
HSFVB	9,010	2/9,010	3/9,010	M / ME	120	SN 420 x 180	1,820	980	341	1,360	275/70 R22.5
HSFVB	9,010	2/9,010	3/9,010	M / ME	120	SN 420 x 180	1,820	900	341	1,360	275/70 R22.5
HSFVB	9,010	2/9,010	3/9,010	M / ME	120	SN 420 x 180	1,880	980	325	1,360	275/70 R22.5
HSFVB	10,010	2/10,010	3/10,010	M / ME	150	SN 420 x 200	2,040	1,300	365	1,360	425/65 R22.5
HSFVB	10,010	2/10,010	3/10,010	M / ME	150	SN 420 x 200	2,000	1,200	325	1,360	425/65 R22.5
HZFVB	10,010	2/10,010	3/10,010	M / ME	150	SN 420 x 200	1,820	900	261	1,360	275/70 R22.5
HZFVB	10,010	2/10,010	3/10,010	M / ME	150	SN 420 x 200	1,820	980	261	1,360	275/70 R22.5
HZFVB	10,010	2/10,010	3/10,010	M / ME	150	SN 420 x 200	1,850	980	241	1,360	275/70 R22.5
HZFVB		2/10,010		M / ME	150	SN 420 x 200	1,820	900	261	1,820	275/70 R22.5
HZFVB		2/10,010		M / ME	150	SN 420 x 200	1,820	980	261	1,820	275/70 R22.5
HZFVB		2/10,010		M / ME	150	SN 420 x 200	1,850	980	241	1,820	275/70 R22.5
HSFVB	12,010	2/12,010	3/12,010	M / ME	150	SN 420 x 200	2,040	1,300	365	1,360	445/65 R22.5
HSFVB	12,010	2/12,010	3/12,010	M / ME	150	SN 420 x 200	2,000	1,200	325	1,360	445/65 R22.5
HZFVB	12,010	2/12,010	3/12,010	M / ME	150	SN 420 x 200	1,820	900	261	1,360	295/80 R22.5
HZFVB	12,010	2/12,010	3/12,010	M / ME	150	SN 420 x 200	1,820	980	261	1,360	295/80 R22.5
HZFVB	12,010	2/12,010	3/12,010	M / ME	150	SN 420 x 200	1,850	980	241	1,360	295/80 R22.5
HZFVB		2/12,010		M / ME	150	SN 420 x 200	1,820	900	261	1,820	295/80 R22.5
HZFVB		2/12,010		M / ME	150	SN 420 x 200	1,820	980	365	1,820	295/80 R22.5
HZFVB		2/12,010		M / ME	150	SN 420 x 200	1,850	980	241	1,820	295/80 R22.5

<sup>1)</sup> Trilex versions: Type designation HIZVB ... The track widths vary depending on the tyre size and spacer ring.

<sup>2)</sup> M: Equaliser bearing in rubber/steel bushes / ME: Equaliser bearing in bronze bushes, 40 mm lower versions ..MN / ..MNE: with shortened supports on request.

<sup>3)</sup> Note the tyre manufacturer's information regarding load index and dimensions.

<sup>4)</sup> Take account of the clearance for dynamic upward travel and equalising distance on suspension axles.

<sup>5)</sup> Weight without wheels and tyres; weight deviations are within the permitted DIN tolerances for the corresponding production processes.

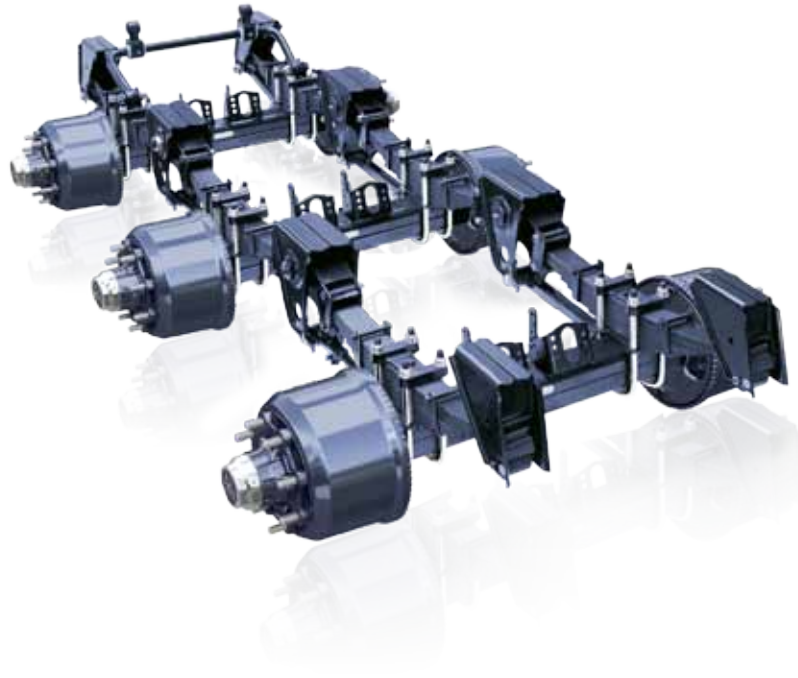

M = Centre-to-centre distance. ET = Offset	Overall width across the tyres (mm)	Wheel connection		Ride height (FH) (mm)				Weights of suspension <sup>5)</sup> (kg)		
				with multi-leaf spring		with parabolic spring		(Version M with parabolic springs)		
		Wheel stud	Ø H/K (mm)	Laden <sup>4)</sup>	Unladen	Laden <sup>4)</sup>	Unladen	Single axle	Tandem-axle suspension	Tri-axle suspension
0 offset	2,405	10 x M22 x 1.5	280.8 / 335	382	424	378	413	496	1,035	1,545
0 offset	2,435	10 x M22 x 1.5	280.8 / 335	382	424	378	413	497	1,037	1,548
0 offset	2,435	10 x M22 x 1.5	280.8 / 335	382	424	378	413	497	1,037	1,548
0 offset	2,490	10 x M22 x 1.5	280.8 / 335	382	424	378	413	499	1,041	1,554
M = 320	2,432	10 x M22 x 1.5	280.8 / 335	382	424	378	413	505	1,053	1,572
M = 320	2,432	10 x M22 x 1.5	280.8 / 335	382	424	378	413	505	1,053	1,572
M = 320	2,492	10 x M22 x 1.5	280.8 / 335	382	424	378	413	508	1,059	1,581
0 offset	2,475	10 x M22 x 1.5	280.8 / 335	397	439	406	429	545	1,114	1,693
0 offset	2,435	10 x M22 x 1.5	280.8 / 335	397	439	406	429	543	1,110	1,687
M = 320	2,432	10 x M22 x 1.5	280.8 / 335	397	439	406	429	545	1,114	1,693
M = 320	2,432	10 x M22 x 1.5	280.8 / 335	397	439	406	429	545	1,114	1,693
M = 320	2,462	10 x M22 x 1.5	280.8 / 335	397	439	406	429	547	1,118	1,699
M = 320	2,432	10 x M22 x 1.5	280.8 / 335	397	439	406	429		1,148	
M = 320	2,432	10 x M22 x 1.5	280.8 / 335	397	439	406	429		1,148	
M = 320	2,462	10 x M22 x 1.5	280.8 / 335	397	439	406	429		1,152	
0 offset	2,505	10 x M22 x 1.5	280.8 / 335	394	436	417	444	540	1,097	1,660
0 offset	2,465	10 x M22 x 1.5	280.8 / 335	394	436	417	444	538	1,093	1,654
M = 330	2,465	10 x M22 x 1.5	280.8 / 335	394	436	417	444	540	1,097	1,660
M = 330	2,465	10 x M22 x 1.5	280.8 / 335	394	436	417	444	540	1,097	1,660
M = 330	2,495	10 x M22 x 1.5	280.8 / 335	394	436	417	444	542	1,101	1,666
M = 330	2,465	10 x M22 x 1.5	280.8 / 335	394	436	417	444		1,136	
M = 330	2,465	10 x M22 x 1.5	280.8 / 335	394	436	417	444		1,136	
M = 330	2,495	10 x M22 x 1.5	280.8 / 335	394	436	417	444		1,140	

**More information:**

► VB suspension units (page 53)

# BPW VB series axle units.

Axle loads from 14,000 kg to 20,000 kg.

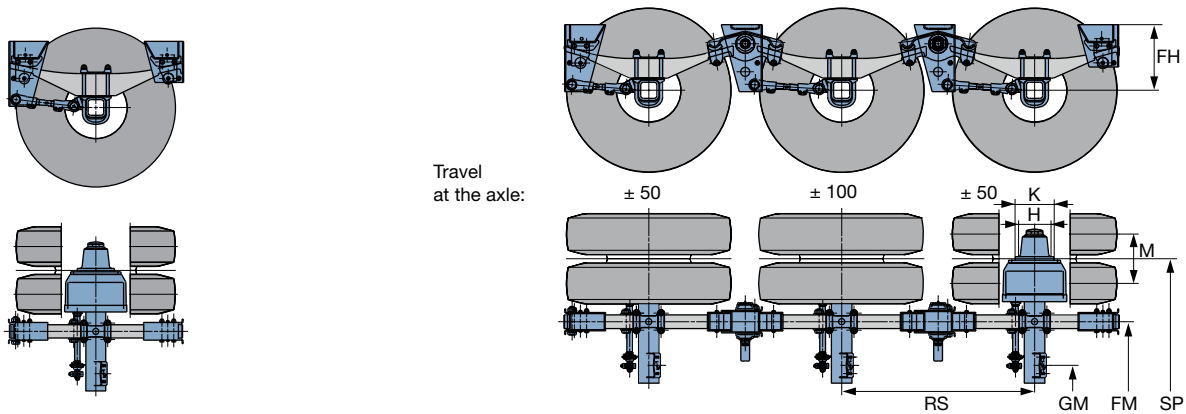

Type <sup>1)</sup>	Single axle	Tandem-axle suspension	Triaxle unit	Version <sup>2)</sup>	S-cam brake Ø x width	Track (SP) (mm)	Spring centre (FM) (mm)	GM (mm)	Wheelbase (RS) <sup>3)</sup> (mm)	Tyre example <sup>4)</sup> (mm)
HZFVB		2/14,010	3/14,010	HD/HDE	SN 420 x 200	1,820	900	266	1,360	12 R20
HZFVB		2/14,010	3/14,010	HD/HDE	SN 420 x 200	1,820	900	266	1,410	12 R24
HZFVB	14,010	2/14,010	3/14,010	HD/HDE	SN 420 x 200	1,820	900	266	1,500	12 R24
HZMVB		2/16,010	3/16,010	HDE	SN 420 x 200	1,820	900	261	1,360	12 R20
HZMVB		2/16,010	3/16,010	HDE	SN 420 x 200	1,950	900	281	1,410	12 R24
HZMVB		2/16,010	3/16,010	HDE	SN 420 x 200	2,250	1,200	505	1,500	12 R24
HZMVB	16,010	2/16,010	3/16,010	HDE	SN 420 x 200	1,820	900	261	1,500	12 R24
HZMVB	18,010	2/18,010	3/18,010	HDE	SN 420 x 200	1,820	900	261	1,500	12 R24
HZMVB	18,010	2/18,010	3/18,010	HDE	SN 420 x 200	1,950	900	281	1,500	14 R20
HZMVB	18,010	2/18,010	3/18,010	HDE	SN 420 x 200	2,320	1,200	407	1,500	14 R20
HZMVB	20,010	2/20,010	3/20,010	HDE	SN 420 x 200	1,950	900	278	1,500	14 R20
HZMVB	20,010	2/20,010	3/20,010	HDE	SN 420 x 200	2,200	1,100	354	1,500	14 R20
HZMVB	20,010	2/20,010	3/20,010	HDE	SN 420 x 200	2,400	1,300	554	1,500	14 R20

Also available as Trilex version

<sup>1)</sup> Trilex versions: Type designation HIZVB ... The track widths vary depending on the tyre size and spacer ring.

<sup>2)</sup> HD: Equaliser bearing in rubber/steel bushes / HDE: Equaliser bearing in bronze bushes.

<sup>3)</sup> Wheelbase 2,050 on request.

<sup>4)</sup> Note the tyre manufacturer's information regarding load index and dimensions.

<sup>5)</sup> Take account of the clearance for dynamic upward travel and equalising distance on suspension axles.

<sup>6)</sup> Weight without wheels and tyres; weight deviations are within the permitted DIN tolerances for the corresponding production processes.

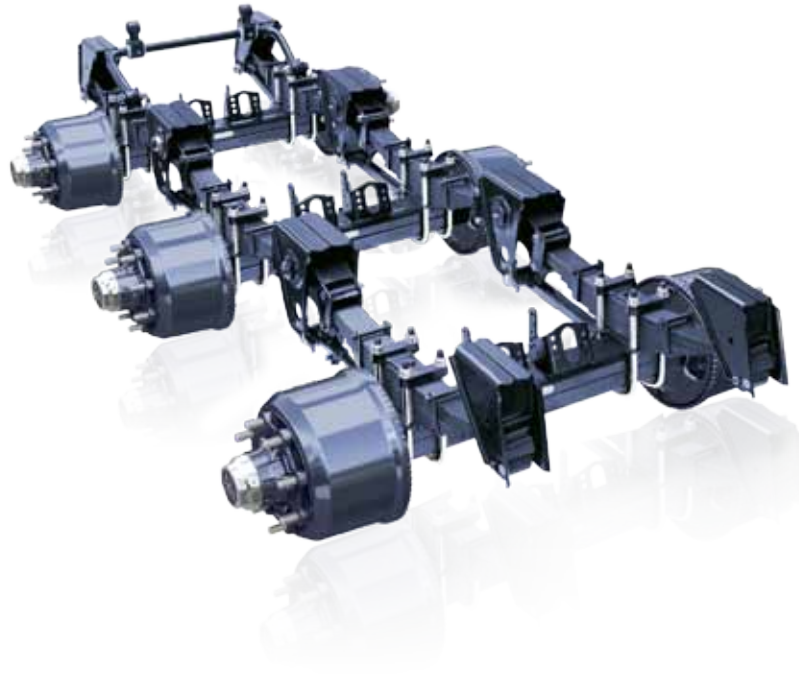

M = Centre-to-centre distance	Overall width across the tyres (mm)	Wheel connection		Ride height FH (mm)		Weights of suspension <sup>9)</sup> (kg)		
		Wheel stud	Ø H/K (mm)	Laden <sup>5)</sup>	Unladen	Single axle	Tandem-axle suspension	Tri-axle suspension
M = 350	2,496	10 x M22 x 1.5	280.8 / 335	430	475		1,527	2,300
M = 360	2,509	10 x M22 x 1.5	280.8 / 335	435	480		1,548	2,331
M = 360	2,509	10 x M22 x 1.5	280.8 / 335	455	500	814	1,592	2,432
M = 350	2,496	10 x M22 x 1.5	280.8 / 335	475	500		1,640	2,469
M = 360	2,639	10 x M22 x 1.5	280.8 / 335	460	495		1,678	2,525
M = 360	2,939	10 x M22 x 1.5	280.8 / 335	490	530		1,767	2,659
M = 360	2,509	10 x M22 x 1.5	280.8 / 335	490	530	864	1,715	2,581
M = 360	2,496	10 x M22 x 1.5	280.8 / 335	460	480		1,735	2,612
M = 428	2,776	10 x M22 x 1.5	280.8 / 335	460	480		1,757	2,645
M = 428	3,146	10 x M22 x 1.5	280.8 / 335	460	480	940	1,817	2,735
M = 428	2,776	10 x M24 x 1.5	280.8 / 335	455	480		1,885	2,837
M = 428	3,026	10 x M24 x 1.5	280.8 / 335	455	480		1,931	2,906
M = 428	3,226	10 x M24 x 1.5	280.8 / 335	455	480	1,015	1,967	2,960

**More information:**

► VB suspension units (page 53)